

Product specification



Model: SK-ST2Q60V24-CCx

15M SUPER LENGTH CC LED STRIP



SMD
2835



Product Features

Constant current technology protects each LED against voltage drop, keeping same brightness from the beginning to the end; just feed on one supply saved much on installation; Max Length 50M in one Roll;

- Using top tpistar 2835 with high lumen, pure copper 3oz PCB for good heat;
- Built-in constant current IC with temperature sensing function;
- 10/15/20M on one supply by constant voltage driver;
- IP65/IP67/IP68 rating by silicone extrusion machine, perfect appearance and no color shift;
- Dimmable, easy cutting and soldered;



Structure & Parameter

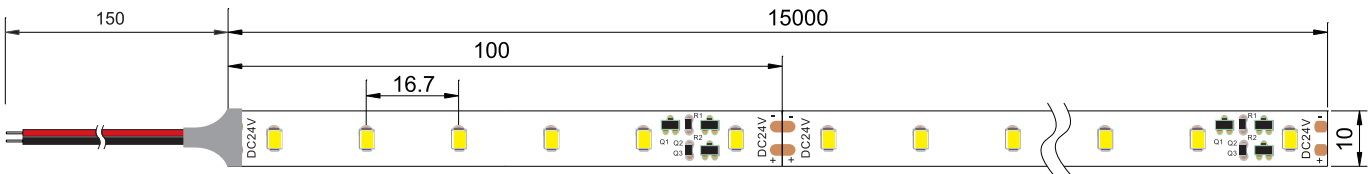

Optical Parameter

Model No.	SK-ST2Q60V24-CCx
Input voltage	DC 24V
Power/m	10.5w
Max current / LED	44mA
CRI(Ra)	>80Ra
Color temperature	2700~6500K
Lumen / m	1176~1328LM

Basic Parameter

LED Q'ty/m	60LEDs/m
SMD Type	2835
Working hour	50000h
Warranty	5years
Working temperature	-20°C ~ +45°C
Minim cuttable length	100mm
PCB Width	10mm

Bin Range of Chromaticity Coordinate

CCT	Bin code Bin		CIE-X	CIE-Y
6500k	65B	6200-6800	0.313	0.337
6000K	60B	5800-6300	0.322	0.336
5000K	50B	4800-5200	0.346	0.359
4000K	40B	3800-4200	0.380	0.380
3500k	35B	3250-3650	0.409	0.394
3000K	30B	2900-3100	0.44	0.403
2700K	27B	2600-2800	0.463	0.42

CIE Chromaticity Diagram

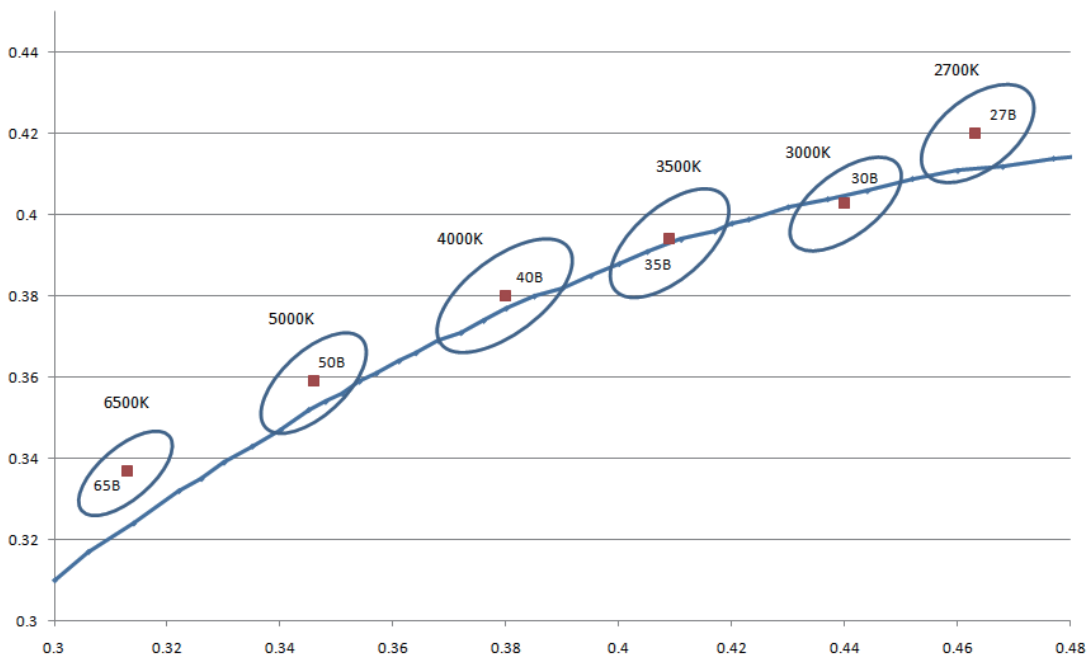

Voltage & Current Curve

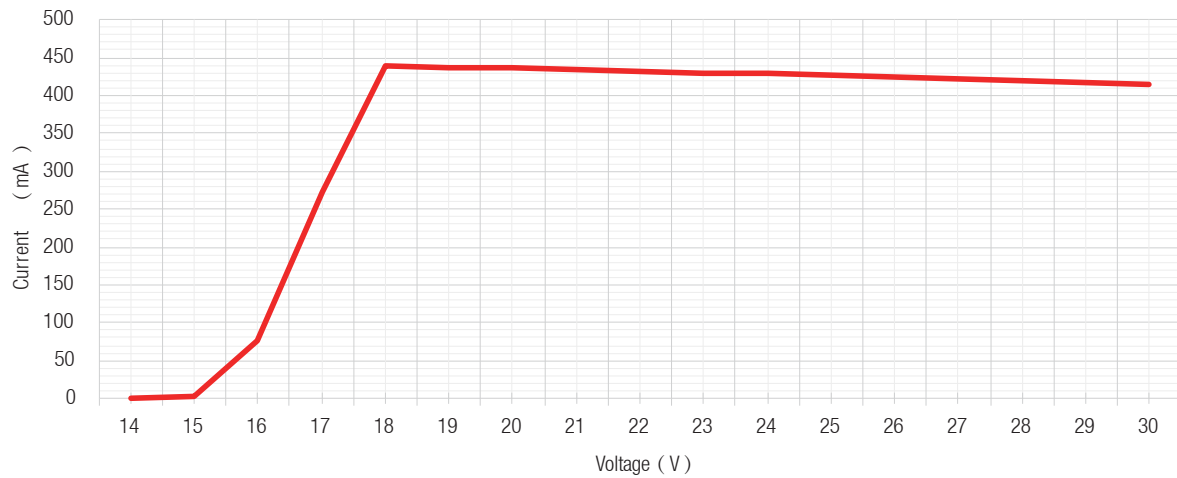

Note: This curve is tested when the IP20 1M LED Strip is under thermal stability after 2h continuous working in 15 C room temperature.

Temperature & Current Curve

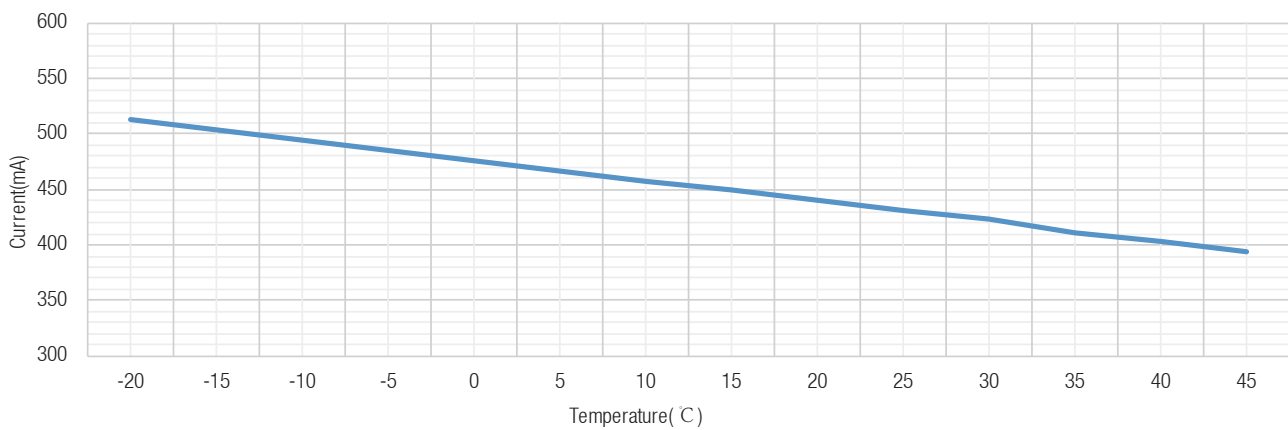

Note: This curve is test data of 1M LED Strip.

Light Distribution Curve

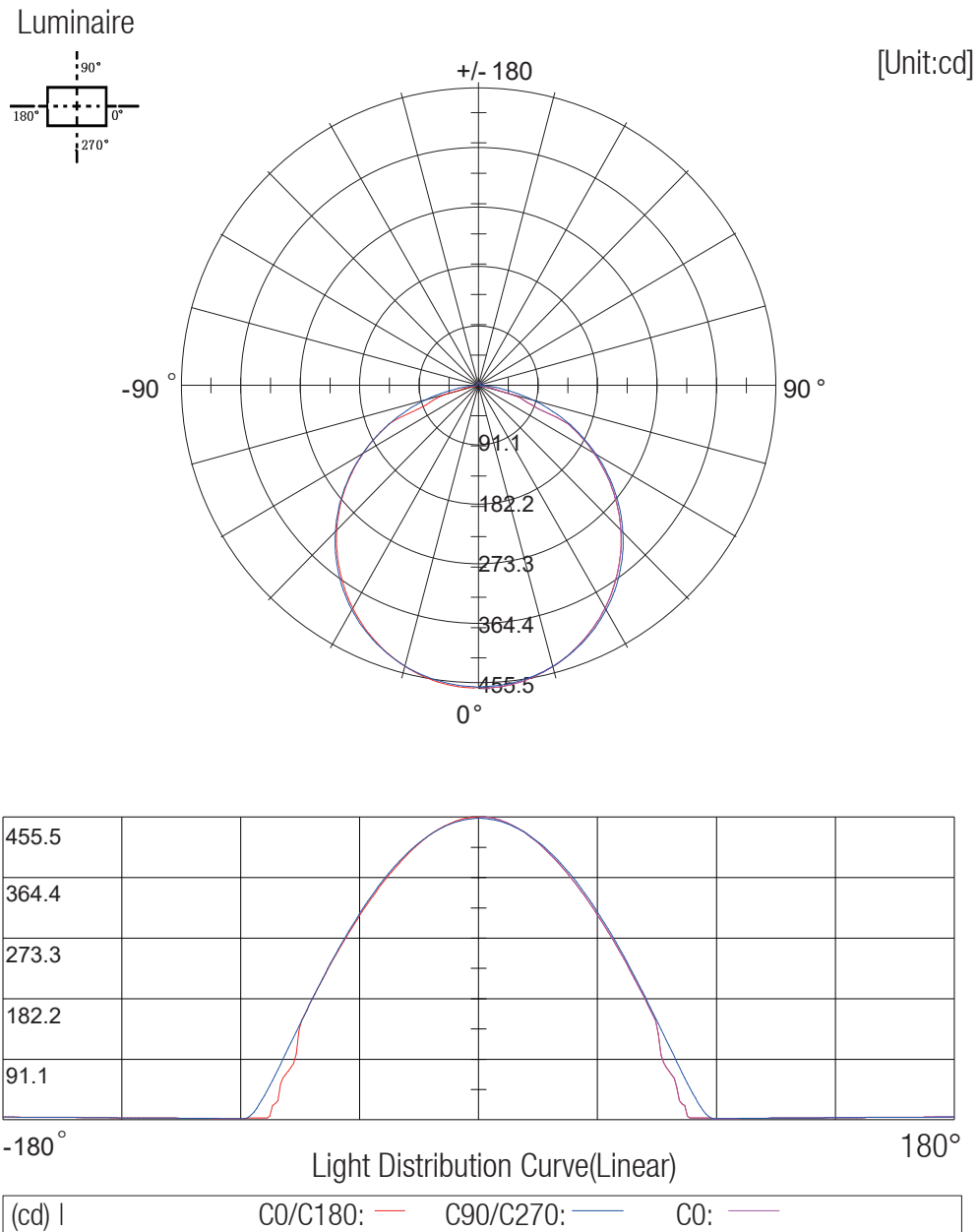

Lux–Distance Curve

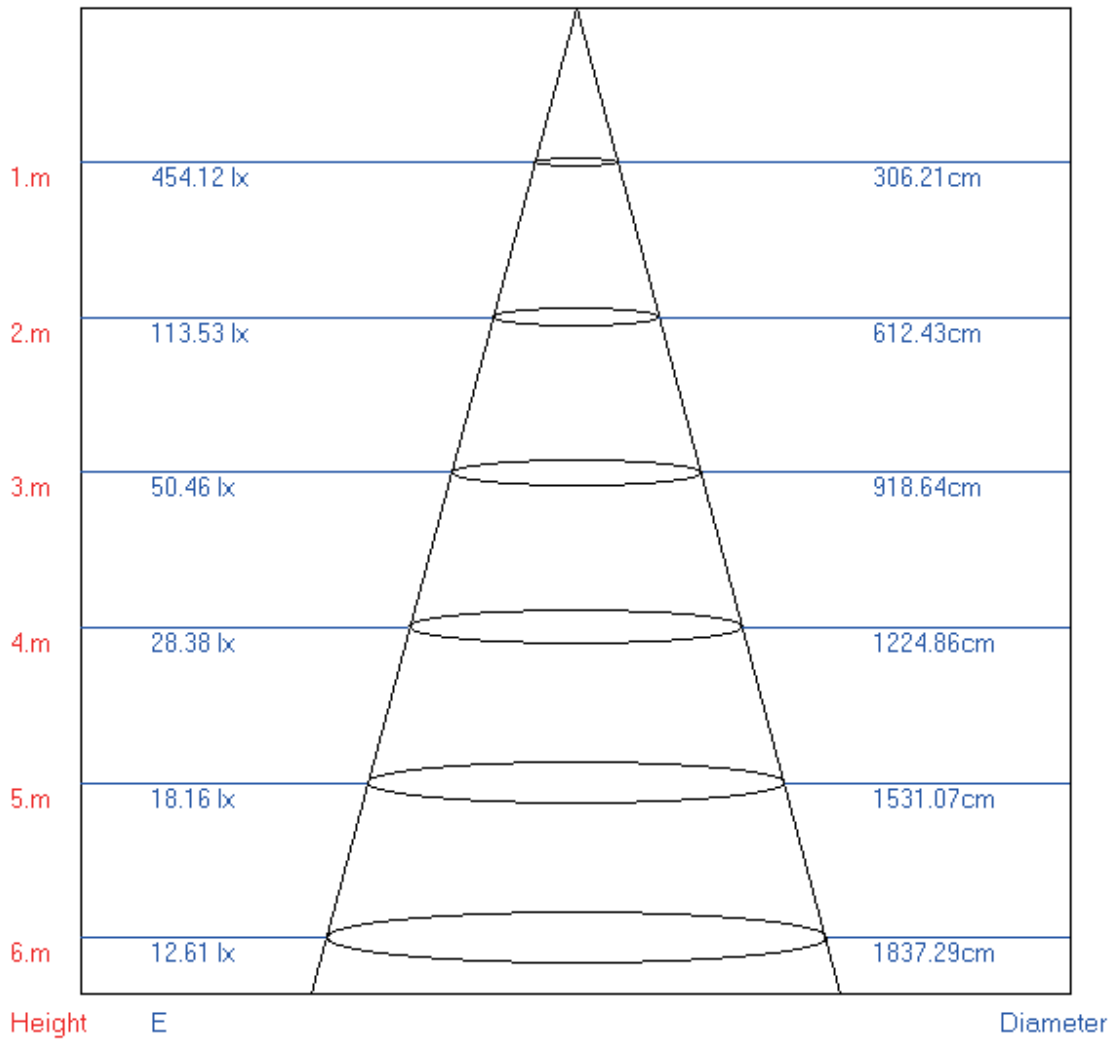

Beam Angle:113.40°

Wiring Diagram (1)

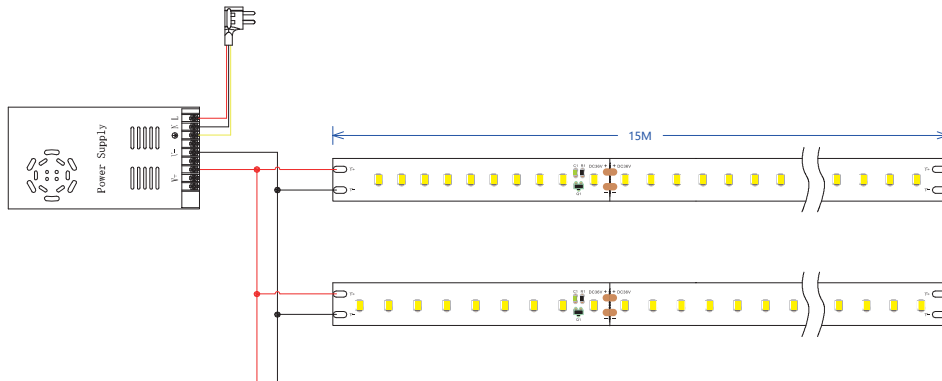

Wiring Diagram (2)

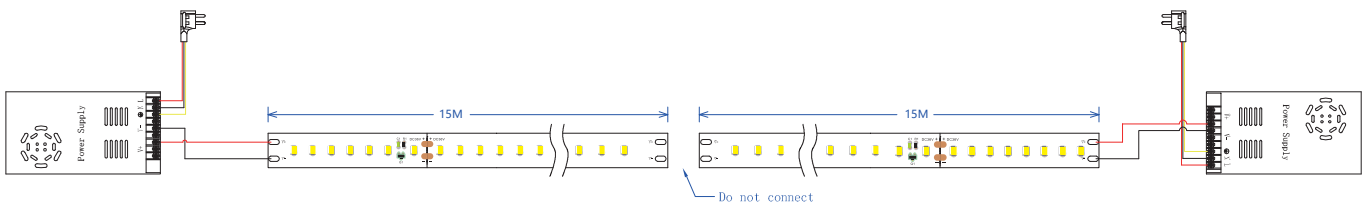

Wiring Diagram (3)

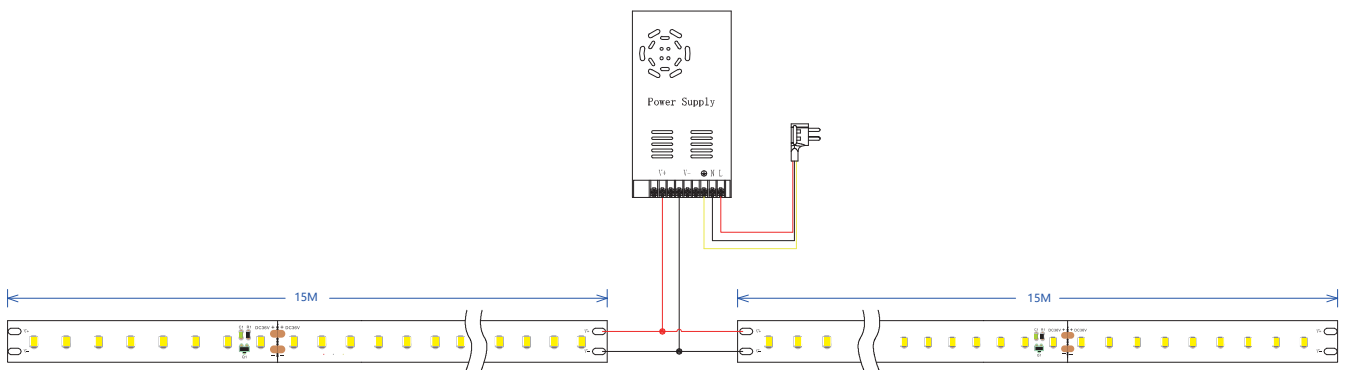

! Cautions

When install the led strip,please note the installation technique.The led strip can be bent,but not distorted,as shown below.

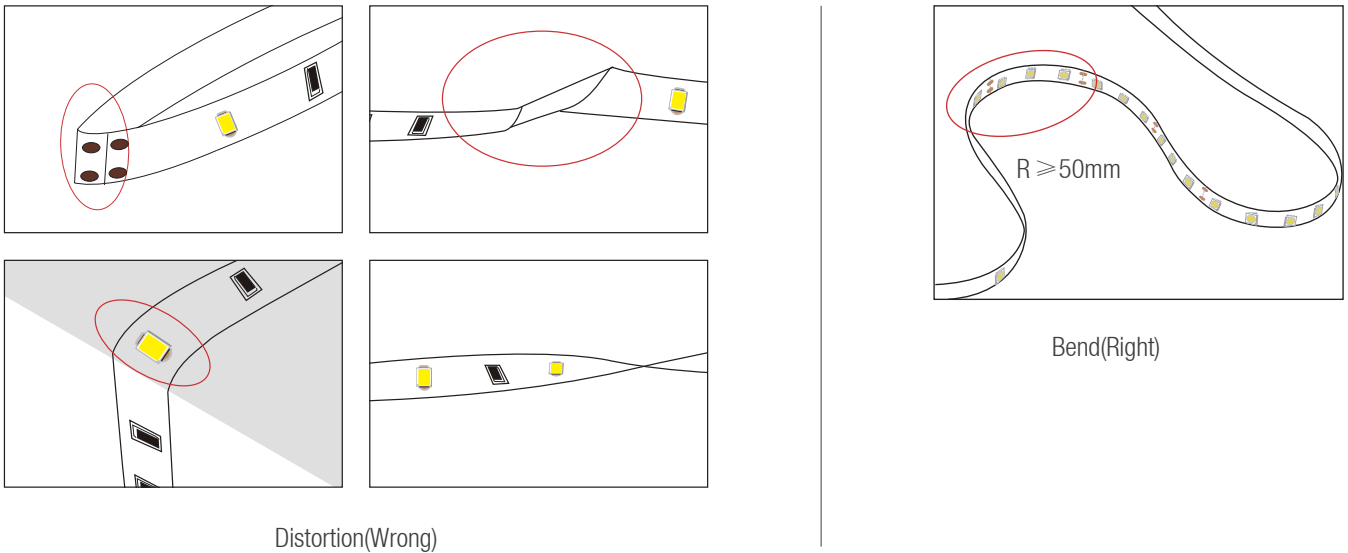

➤ LED strips are low voltage products,you must use the power supply(transformer).Please don,t connect the led strip directly to the AC 110v or AC 220v,otherwise it will burn out the LED strips.

➤ Clean up the installation surface,it will ensure the reliability of the adhesive,The electrical connection process must be operated by a professional person.

Package

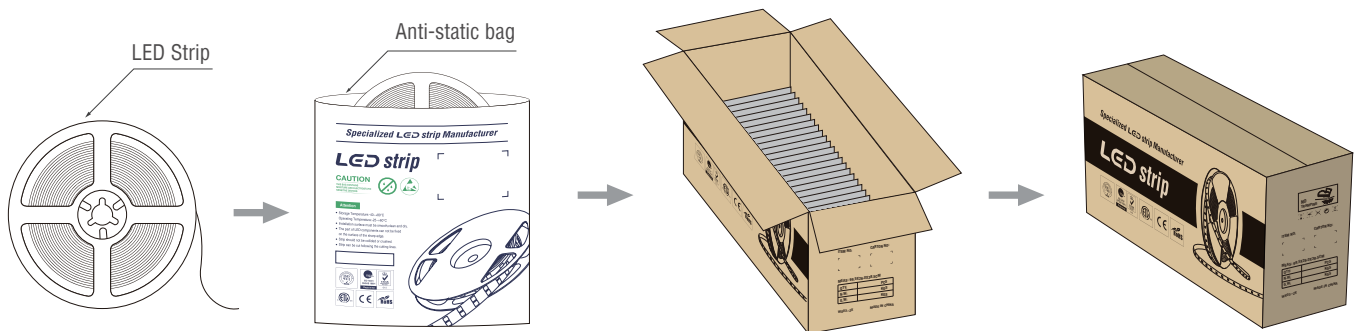

S H I N E S K Y

**Specialized
LED strip
Manufacturer**

SHENZHEN SHINESKY OPTOELECTRONICS CO.,LTD



Building 29, Shancheng Industrial Park, Shiyan Street, Bao'an District,
Shenzhen, Guangdong, China.



OUR EMAIL

director@shineskygroup.com



OUR PHONE

Tel: 0755-29516255



OUR WEBSITE

Web: www.xskled.com